

- B.3 Selection table RCCB's and RCBO's
- B.4 Technical data
- B.6 Association of RCCB's
- B.7 Coordination of RCCB's
- B.7 Power losses

Miniature circuit breakers A

Residual current circuit breaker B

B.8 Residual current circuit breakers

Busbar systems C

- B.9 EHFI - Type A
- B.9 EFI - Type AC
- B.9 ESHFI - Type S
- B.10 EHFI...i - Type Ai
- B.10 EHSFI...i - Type Si
- B.10 EFI...S - Type AC

Comfort functions/Energy control D

Residential enclosures E

B.12 Residual current circuit breakers with overcurrent protection

Contactors/Soft starters/Speed drives F

- B.13 HD90 - Type A
- B.13 D90 - Type AC
- B.15 HD90S - Type A
- B.15 D90S - Type AC
- B.17 DE90 - Type AC
- B.17 DE90S - Type AC
- B.18 HD62/HD63N

Overload relays G

Control and signalling units H

B.20 Add-on residual current circuit breakers for MCB's Series E90 and E880

Limit switches I

- B.21 HD92/93/94/95 - Type A
- B.21 HDS92/93/94/95 - Type A
- B.21 D92/93/94/95 - Type AC
- B.21 DS92/93/94/95 - Type AC

Manual motor starters J

B.22 Screwless & Plug-in RCCB's - Fixwell™

Moulded case circuit breakers K

- B.22 EHFIP - Type A
- B.22 ESHFIP - Type S
- B.24 Technical data
- B.25 Terminal capacity

Air circuit breakers L

B.26 TeleREC - Reconnection relays

Fuse systems/Loadbreak disconnectors M

- B.26 Characteristics
- B.27 TeleREC PLUS
- B.28 TeleREC BASIC
- B.28 TeleREC SOLAR
- B.29 Dimensional drawings

Industrial enclosures N

Wiring devices O

Numerical index X

Notes

A large grid area for taking notes, consisting of a 20x30 grid of small squares. The grid is empty and occupies the majority of the page.

Selection table RCCB's

Page No.	Series	Sensitivity (mA)	Poles	Type	Nominal current (A)						Isolator appl.	Add-on devices	Rated voltage (V)			
					16	25	40	63	80	100						
B.8	FI															
	EH/EFI	10	2P	AC/A									x	x	240	
	EH/EFI	30	2P	AC/A									x	x	240	
	EHF			Ai									x	x	240	
	EH/EFI		4P	AC/A									x	x	240/415	
	EHF			Ai									x	x	240/415	
	EH/EFI	100	2P	AC/A/S									x	x	240	
			4P	AC/A/S									x	x	240/415	
	EH/EFI	300	2P	AC/A/S/Si									x	x	240	
			4P	AC/A/S/Si									x	x	240/415	
	EH/EFI	500	2P	AC/A/S									x	x	240	
			4P	AC/A/S									x	x	240/415	

Selection table RCBO's - 6 kA

Page No.	Series	Sensitivity (mA)	Pole	Type	Tripping charact.	Nominal current (A)								Isolator appl.	Add-on devices	Rated voltage (V)			
						4	6	10	13	16	20	25	32				40		
B.14	D/HD																		
	D/HD90	10	1+N	AC/A	B												x	x	230
					C												x	x	230
	D/HD90	30	1+N	AC/A	B												x	x	230
					C												x	x	230
	D/HD90	300	1+N	AC/A	B												x	x	230
					C												x	x	230
B.16	DE																		
	DE90	30	1+N	AC	C												x	x	230
	DE90S	30	1+N	AC	C												x	x	230
B.18	HD																		
	HD62	30	2P		B/C														
	HD63N	30	3P+N		C														

Selection table RCBO's - 10 kA

Page No.	Series	Sensitivity (mA)	Pole	Type	Tripping charact.	Nominal current (A)								Isolator appl.	Add-on devices	Rated voltage (V)				
						4	6	10	13	16	20	25	32				40			
B.14	D/HD																			
	D/HD90S	10	1+N	AC/A	B													x	x	230
					C													x	x	230
	D/HD90S	30	1+N	AC/A	B													x	x	230
					C													x	x	230
	D/HD90S	300	1+N	AC/A	B													x	x	230
					C													x	x	230

Selection table for Add-on RCCB's

Page No.	Series	Sensitivity (mA)	Pole	Type	Nominal current (A)		Rated voltage (V)
					32	63	
B.20							
	HD/D92-94	30	2-3-4	AC/A			240/415
	HD/DS	300	2-3-4	AC/A/S			240/415

Overview technical data RCD's

Series			E/EHFI (DFI)	D/HD90
Standards			EN/IEC 61008-1	EN/IEC 61009-1
Magnetic tripping characteristics			-	B-C
Residual tripping characteristic			AC, A, S, Ai, Si	A, AC
Tripping time at I Δ n	Instantaneous	ms	<40	<40
	Selective	ms	>150	-
Rated current			16, 25, 40, 63, 80, 100	4, 6, 10, 13, 16, 20, 25, 32, 40
Rated residual current I Δ n			10, 30, 100, 300, 500	10, 30, 300
Calibration temperature			30	30
Number of poles versus modules			1	1
Rated voltage Un	2PAC	V	240	230 (1P+N)
	3P AC	V	-	-
	4P AC	V	415	-
Frequency			50/60	50/60
Maximum service voltage U $_{bmax}$			2P=265 / 4P=455	255
Minimum service voltage U $_{bmin}$			2P=117 / 4P=205	117
Power supply			Top/Bottom	Top/Bottom
Selectivity class			-	3
Rated making and breaking capacity (I $_m$)			500 (or 10xI $_n$)	-
Residual making and breaking capacity (I Δ m)			500 (or 10xI $_n$)	6000
Conditional short-circuit capacity (I $_c$)			10000 fuse 100A	-
Conditional residual short-circuit capacity (I Δ c)			10000	-
Rated Short-circuit capacity (I $_cn$)			-	6000
Grid distance (safety distance between two devices)			35	35
Isolator application			yes	yes
Insulation degree	Insulation voltage	V (DC)	500	500
	Shock voltage (1.2/50ms)	kV	8	6
	Insulation resistance	(mOhm)	1000	1000
	Dielectric strength	V	2500	2500
Shock resistance (in x, y, z direction)(EN/IEC 60077/16.3)			40g, 18 shocks 5 ms	40g, 18 shocks 5 ms
Vibration resistance (in x, y, z direction; EN/IEC 60068-2-6)			1.5g, 30 min, 0...80Hz	1.5g, 30 min, 0...80Hz
Endurance	electrical at Un, I $_n$		10000	10000
	mechanical at Un, I $_n$		20000	20000
Protection degree (outside/inside electrical enclosure)			IP 20 / IP 40	IP 20 / IP 40
Self extinguish degree (according to UL94)			V2	V2
Tropicalisation (according to EN/IEC 60068-2, DIN 40046)			+55/95%	+55/95%
Pollution degree (acc. EN/IEC 60947-1)			3	3
Operating temperature			AC (-5.. +60); A -25.. +60)	-5..+60
Storage temperature			-25..+70	-25..+70
Terminals capacity	Rigid cable min/max (top)	mm ²	1.5/50 [1.5/35]	1/25
	Flexible cable min*/max (top)	mm ²	1.5/35 [1.5/25]	1/16
	Rigid cable min/max (bottom)	mm ²	1.5/50 [1.5/35]	1/35
	Flexible cable min*/max (bottom)	mm ²	1.5/35 [1.5/25]	1/25
	(*Flexible cable 0.75/1/1.5 mm ² with cable lug)			
Torque			5/5	3/4
Add-on devices (side add-on)	Auxiliary contacts		yes	yes
	Remote release		yes	yes
	Undervoltage trip NUVR		yes	yes
	Remote drive NFA		yes	yes
	Panel board switch NLVS		yes	yes
Busbars systems	Pin		yes	Bottom
	Fork		yes	Bottom
Accessories			yes	yes
Dimensions, weights, packaging				
# Poles			2-4	1+N
(HxDxW) 86x68xW			36/72	36
Weight/unit			2P=250 / 4P=368	250
Package/unit			2P=1/6 / 4P=1/3	1/6
Approvals			VDE / KEMA	VDE / KEMA
CE-marking			yes	yes
Page			B.8	B.12

D/HD90S	DE90	DE90S	HD62/HD63N	D/HD92-94
EN/IEC 61009-1	IEC 61009-1	IEC 61009-1	IEC 61009-1	EN/IEC 61009-1
B-C	C	C	2P=B/C - 4P=C	-
A, AC	AC	AC	A	AC-A-S
<40	<40	<40	< 40	<40
-	-	-	-	>150
4,6,10,13,16,20,25,32,40	6...40	6...40	2P=6...32 - 4P=10...25	32, 63
10,30,300	30	30, 100	30	30, 300
30	30	30	30	30
1	1	1	2P=1,5 - 4P=1	1
240 (1P+N)	240 (1P+N)	240 (1P+N)	230	240/415
-	-	-	-	400
-	-	-	400	400
50/60	50/60	50/60	50/60	50/60
255	265	265	2P=255 - 4P=440	2P=265 / 4P=455
117	195	195	2P=127 - 4P=180	2P=205 / 4P=205
Top/Bottom	Bottom	Bottom	Top/Bottom	Top
3	3	3	3	3
-	-	-	-	-
6000	6000	10.000	3000	see MCB
-	-	-	-	-
-	-	-	-	-
10.000	6000	10.000	6000	see MCB
35	-	-	35	35
yes	yes	yes	yes	no
500	500 ⁽¹⁾	500 ⁽¹⁾	500	500
6	6 ⁽¹⁾	6 ⁽¹⁾	6	8
1000	1000 ⁽¹⁾	1000 ⁽¹⁾	1.000	1000
2500	2500 ⁽¹⁾	2500 ⁽¹⁾	2000	2500
40g, 18 shocks 5 ms	40g, 18 shocks 5 ms	40g, 18 shocks 5 ms	40g, 18 shocks, 5ms	40g, 18 shocks 5 ms
1.5g, 30 min, 0...80Hz	2g, 30 min, 0...80Hz	2g, 30 min, 0...80Hz	1,5g, 30min, 0....80Hz	5g, 30 min, 0...80Hz
10000	10000	10000	10000	10000
20000	20000	20000	20000	20000
IP 20 / IP 40	IP20 / IP40	IP20 / IP40	IP20 / IP40	IP 20 / IP 40
V2	V2	V2	V0	V2
+55/95%	+55/95%	+55/95%	+55/95%	+55/95%
3	3	3	2	3
-5...+60	-5...+60	-5...+60	- 25° / + 40°	AC (-5...+60); A(-25...+60)
-25...+70	-25...+70	-25...+70	-25° / + 55°	-25...+70
1/25	1/25	1/25	1/35	1/25
1/16	1/16	1/16	1/25	1/16
1/35	1/35	1/35	1/35	1/35
1/25	1/25	1/25	1/25	1/25
3/4	3	3	3	-/4.5
yes	-	-	-	yes (coupled to MCB)
yes	-	-	-	yes (coupled to MCB)
yes	-	-	-	yes (coupled to MCB)
yes	-	-	-	yes (coupled to MCB)
yes	-	-	-	yes (coupled to MCB)
Bottom	Bottom	Bottom	Bottom	-
Bottom	Bottom	Bottom	Bottom	-
yes	yes	yes	no	yes
-	-	-	-	-
1+N	1+N	1+N	2/3+N	2-3-4
36	18	18	2P= 92 x 54 x 52.5 - 4P= 92 x 68 x 70	72/90/108/125/144
250	350	350	2P=350 - 4P= 480	2P=250 / 3P=320 / 4P=340
1/6	1	1	1	1
VDE / KEMA	KEMA	KEMA	IMQ	KEMA
yes	yes	yes	yes	yes
B.14	B.16	B.16	B.18	B.20

(1) Making sure that N-L and both flying leads are disconnected.

Association of RCCB's

With MCB's - Back-up protection



		E90N	E90E	E90	E90S	E90X	E880	S90
Series EFi/EHFI 2P 230V	16A	3 kA	4.5 kA	10 kA	20 kA	20 kA	10 kA	25 kA
	25A	3 kA	4.5 kA	10 kA	20 kA	20 kA	10 kA	25 kA
	40A	3 kA	4.5 kA	10 kA	20 kA	20 kA	10 kA	25 kA
	63A	-	-	-	20 kA	20 kA	10 kA	25 kA
	80A	-	-	-	-	-	10 kA	25 kA
	100A	-	-	-	-	-	10 kA	25 kA
Series EFi/EHFI 4P 400V	25A	3 kA	4.5 kA	6 kA	10 kA	10 kA	10 kA	25 kA
	40A	3 kA	4.5 kA	6 kA	10 kA	10 kA	10 kA	25 kA
	63A	-	-	-	10 kA	10 kA	10 kA	25 kA
	80A	-	-	-	-	-	10 kA	25 kA
	100A	-	-	-	-	-	10 kA	25 kA

With fuses gL-gG - Back-up protection



		16A	25A	32A	40A	50A	63A	80A	100A
Series EFi/EHFI 2P 230V	16A	100 kA	100 kA	80 kA	50 kA	40 kA	25 kA	16 kA	10 kA
	25A	100 kA	100 kA	80 kA	50 kA	40 kA	25 kA	16 kA	10 kA
	40A	100 kA	100 kA	80 kA	50 kA	40 kA	25 kA	16 kA	10 kA
	63A	100 kA	100 kA	80 kA	50 kA	40 kA	25 kA	16 kA	10 kA
	80A	100 kA	100 kA	80 kA	50 kA	40 kA	25 kA	16 kA	10 kA
	100A	100 kA	100 kA	80 kA	50 kA	40 kA	25 kA	16 kA	10 kA
Series EFi/EHFI 4P 400V	25A	100 kA	100 kA	80 kA	50 kA	40 kA	25 kA	16 kA	10 kA
	40A	100 kA	100 kA	80 kA	50 kA	40 kA	25 kA	16 kA	10 kA
	63A	100 kA	100 kA	80 kA	50 kA	40 kA	25 kA	16 kA	10 kA
	80A	100 kA	100 kA	80 kA	50 kA	40 kA	25 kA	16 kA	10 kA
	100A	100 kA	100 kA	80 kA	50 kA	40 kA	25 kA	16 kA	10 kA

The values indicated in the table are the maximum short-circuit current in kA rms
 SCPD: Short-Circuit Protective Device (MCB or fuse)

Coordination of RCCB's

		UPSTREAM PROTECTION										
		MCB'S						FUSES				
		E90 ≤ 40A	E90S ≤ 40A	E90S > 40A	E90X ≤ 40A	E90X > 40A	E880 80...125A	S90	Fuse 160A	Fuse 250A	Fuse 400A	Fuse 630A
DOWNSTREAM	Series EFI/EHFI											
	E90 ≤ 25A	6 kA	10 kA	10 kA	10 kA	10 kA	-	25 kA	-	-	-	-
	E90S ≤ 25A	-	25 kA	25 kA	25 kA	25 kA	10 kA	25 kA	16 kA	10 kA	10 kA	10 kA
	E90 > 25A	-	25 kA	25 kA	25 kA	25 kA	10 kA	25 kA	10 kA	10 kA	10 kA	10 kA
	Fuse 25A	100 kA	100 kA	100 kA	100 kA	100 kA	100 kA	100 kA	100 kA	100 kA	100 kA	100 kA

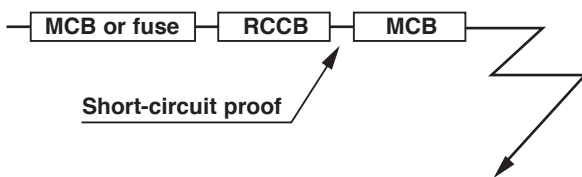

Power losses

	D90/HD90		EFI/EHFI		Add on D/HD92			
	Z mOhm	W/pole	Z mOhm	W/pole	Z mOhm	W/pole		
4A	125.00	2.00	16A	9.94	2.55	32/30	1.56	1.59
6A	53.00	1.91	25A	3.75	2.33	32/30	1.73	1.77
10A	16.30	1.63	40A	2.15	3.43	32/300	1.54	1.57
16A	9.80	2.51	63A	1.30	5.15	32/300	1.70	1.74
20A	7.10	2.84	80A	1.30	8.30	63/30	0.63	2.52
25A	5.60	3.50	100A	0.87	8.70	63/30	0.71	2.82
32A	4.70	4.81				63/300	0.62	2.46
40A	3.60	5.76				63/300	0.70	2.78



RCCB's - Residual current circuit breakers

EN/IEC 61008-1

Series EHF1	For pulsating DC and AC fault currents
Series EFI/DFI	For sinusoidal AC fault currents
Series ESHFI	Time delayed trip for pulsating DC and AC fault currents
Series EFI...S	For sinusoidal AC fault currents. Operates at -25°C
Series EHF1...i	High immunity for pulsating DC and AC fault current
Series EHSFI...i	High immunity time delayed trip for pulsating DC and AC fault current

Applications



Approvals / Marking



Add-on devices

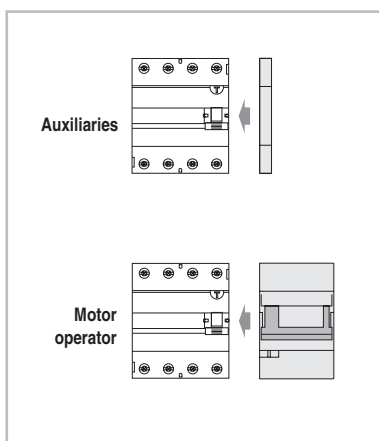

- Auxiliary contacts ● pg A.24
- Shunt trip ● pg A.24
- Undervoltage release ● pg A.24
- Panel board switch ● pg A.24
- Motor operator ● pg A.24

- Busbars ● chapter C
- Dimensions ● pg B.10

Performances

Thermal setting I_n	(A)	16, 25, 40, 63, 80, 100
Residual current $I_{\Delta n}$	(mA)	10, 30, 100, 300, 500
Rated voltage AC U_n	(V)	2P: 240 4P: 240/415
Minimum operating voltage U_{Bmin}	(V)	2P: 117 4P: 205
Mechanical/electrical endurance		20000/10000
Tropicalisation acc.to		
EN/IEC 60068-2-28/2-30 and DIN 40046		95%RH at 55°C
Terminal capacity flexible/rigid cable (mm²)		35-50 ⁽¹⁾
Poles		2, 4
Nuisance tripping resistance		Type A, AC: 250A 8/20μs; 200A 0.5μs - 100kHz Type S: 3000A 8/20μs Type Ai: 3000A 8/20μs Type Si: 5000A 8/20μs
Ambient temperature	(°C)	Type AC: -5 upto 40 Type A: -25 upto 40
Weight	(g)	2P: 220 4P: 385

(1) Series DFI: 25-35 mm²

Short-circuit capacity

Acc. to EN/IEC 61008-1

Making and breaking capacity

$I_m = 500A$ from 16 upto 40A
 $I_m = 10I_n$ from 63 upto 100A

Residual making and breaking capacity

$I_{\Delta m} = 500A$ from 16 upto 40A
 $I_{\Delta m} = 10I_n$ from 63 upto 100A

Short-circuit capacity

$I_{nc} = 10000A$ at 240/415V
fuse 80A gG

Series EHF1 - EFI - ESHFI

Resistance to surge currents up to 250A

2P

127-230V

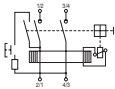

Rated current [A]	Rated fault current [mA]	EHF1 Type A		EFI Type AC		Pack.
		Cat. No.	Ref. No.	Cat. No.	Ref. No.	
16	10	EHF16/010-2	604941	EFI16/010-2	604446	6
25	30	EHF25/030-2	604942	DFI25/030-2	607130	6
40	30	EHF40/030-2	604943	DFI40/030-2	607131	6
63	30	EHF63/030-2	604944	EFI63/030-2	604449	6
80	30	EHF80/030-2	604945	EFI80/030-2	604450	6
100	30	EHF100/030-2	604946	EFI100/030-2	604451	6
25	100	EHF25/100-2	604947	EFI25/100-2	604455	6
40	100	EHF40/100-2	604948	EFI40/100-2	604456	6
63	100	EHF63/100-2	604949	EFI63/100-2	604457	6
80	100	EHF80/100-2	604950	EFI80/100-2	604458	6
100	100	EHF100/100-2	604951	EFI100/100-2	604459	6
25	300	EHF25/300-2	604416	DFI25/300-2	607132	6
40	300	EHF40/300-2	604417	DFI40/300-2	607133	6
63	300	EHF63/300-2	604418	EFI63/300-2	604465	6
80	300	EHF80/300-2	604419	EFI80/300-2	604466	6
100	300	EHF100/300-2	604420	EFI100/300-2	604467	6
25	500	EHF25/500-2	604426	EFI25/500-2	604468	6
40	500	EHF40/500-2	604427	EFI40/500-2	604469	6
63	500	EHF63/500-2	604428	EFI63/500-2	604470	6
80	500	EHF80/500-2	604429	EFI80/500-2	604471	6
100	500	EHF100/500-2	604430	EFI100/500-2	604472	6

4P

230-400V

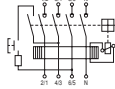

25	30	EHF25/030-4	604478	EFI25/030-4	604523	3
40	30	EHF40/030-4	604479	EFI40/030-4	604524	3
63	30	EHF63/030-4	604480	EFI63/030-4	604525	3
80	30	EHF80/030-4	604481	EFI80/030-4	604526	3
100	30	EHF100/030-4	604482	EFI100/030-4	604527	3
25	100	EHF25/100-4	604483	EFI25/100-4	604531	3
40	100	EHF40/100-4	604484	EFI40/100-4	604532	3
63	100	EHF63/100-4	604485	EFI63/100-4	604533	3
80	100	EHF80/100-4	604486	EFI80/100-4	604534	3
100	100	EHF100/100-4	604487	EFI100/100-4	604535	3
25	300	EHF25/300-4	604493	EFI25/300-4	604539	3
40	300	EHF40/300-4	604494	EFI40/300-4	604540	3
63	300	EHF63/300-4	604495	EFI63/300-4	604541	3
80	300	EHF80/300-4	604496	EFI80/300-4	604542	3
100	300	EHF100/300-4	604497	EFI100/300-4	604543	3
25	500	EHF25/500-4	604503	EFI25/500-4	604544	3
40	500	EHF40/500-4	604504	EFI40/500-4	604545	3
63	500	EHF63/500-4	604505	EFI63/500-4	604546	3
80	500	EHF80/500-4	604506	EFI80/500-4	604547	3
100	500	EHF100/500-4	604507	EFI100/500-4	604548	3

Resistance to surge currents up to 500A

2P

127-230V

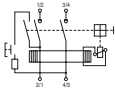

		ESHFI Type S				
25	300	ESHFI25/300-2	604421	-	-	6
40	300	ESHFI40/300-2	604422	-	-	6
63	300	ESHFI63/300-2	604423	-	-	6
80	300	ESHFI80/300-2	604424	-	-	6
100	300	ESHFI100/300-2	604425	-	-	6
25	500	ESHFI25/500-2	604431	-	-	6
40	500	ESHFI40/500-2	604432	-	-	6
63	500	ESHFI63/500-2	604433	-	-	6
80	500	ESHFI80/500-2	604434	-	-	6
100	500	ESHFI100/500-2	604435	-	-	6

4P

230-400V

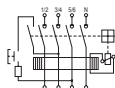

25	300	ESHFI25/300-4	604498	-	-	3
40	300	ESHFI40/300-4	604499	-	-	3
63	300	ESHFI63/300-4	604500	-	-	3
80	300	ESHFI80/300-4	604501	-	-	3
100	300	ESHFI100/300-4	604502	-	-	3
25	500	ESHFI25/500-4	604508	-	-	3
40	500	ESHFI40/500-4	604509	-	-	3
63	500	ESHFI63/500-4	604510	-	-	3
80	500	ESHFI80/500-4	604511	-	-	3
100	500	ESHFI100/500-4	604512	-	-	3

Series EHF1 - EFI - ESHFI

B

Series EHFI.....i - EHSFI.....i

High immunity
to surge currents



2P

127-240V

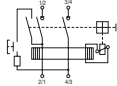

4P

240-400V

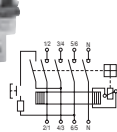

Rated current [A]	Rated fault current [mA]	EHFI Type Ai		EHSFI Type Si		Pack.
		Cat. No.	Ref. No.	Cat. No.	Ref. No.	
25	30	EHFI 25/030-2i	605120	-	-	6
40	30	EHFI 40/030-2i	605121	-	-	6
63	30	EHFI 63/030-2i	605122	-	-	6
25	300	-	-	ESHFI 25/300-2i	605185	6
40	300	-	-	ESHFI 40/300-2i	605186	6
63	300	-	-	ESHFI 63/300-2i	605187	6
80	300	-	-	ESHFI 80/300-2i	605188	6
100	300	-	-	ESHFI 100/300-2i	605189	6
25	30	EHFI 25/030-4i	605123	-	-	3
40	30	EHFI 40/030-4i	605124	-	-	3
63	30	EHFI 63/030-4i	605125	-	-	3
25	300	-	-	ESHFI 25/300-4i	605205	3
40	300	-	-	ESHFI 40/300-4i	605206	3
63	300	-	-	ESHFI 63/300-4i	605207	3
80	300	-	-	ESHFI 80/300-4i	605208	3
100	300	-	-	ESHFI 100/300-4i	605209	3

Rated current [A]	Rated fault current [mA]	-		EFI...S Type AC		Pack.
		Cat. No.	Ref. No.	Cat. No.	Ref. No.	
25	30	-	-	DFI25/030-2S	607155	6
40	30	-	-	DFI40/030-2S	607156	6
63	30	-	-	EFI63/030-2S	604567	6
25	300	-	-	DFI25/300-2S	607157	6
40	300	-	-	DFI40/300-2S	607158	6
63	300	-	-	EFI63/300-2S	604570	6
25	30	-	-	EFI25/030-4S	604571	3
40	30	-	-	EFI40/030-4S	604572	3
63	30	-	-	EFI63/030-4S	604573	3
25	300	-	-	EFI25/300-4S	604574	3
40	300	-	-	EFI40/300-4S	604575	3
63	300	-	-	EFI63/300-4S	604576	3

Operates at -25°C



2P

127-230V

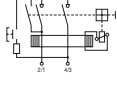

4P

230-400V

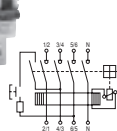

Dimensions

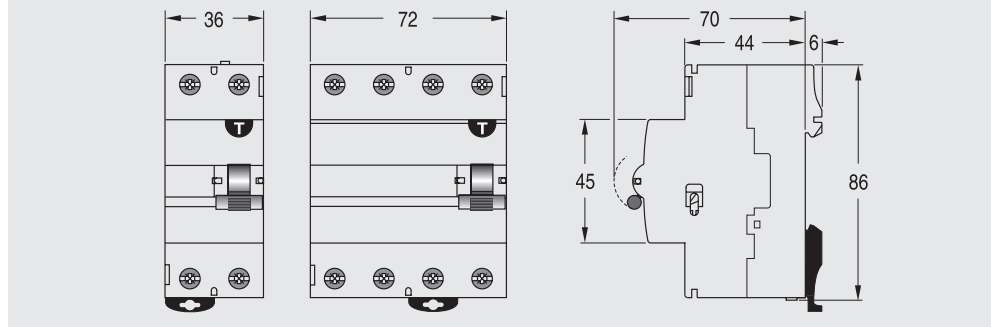

Notes

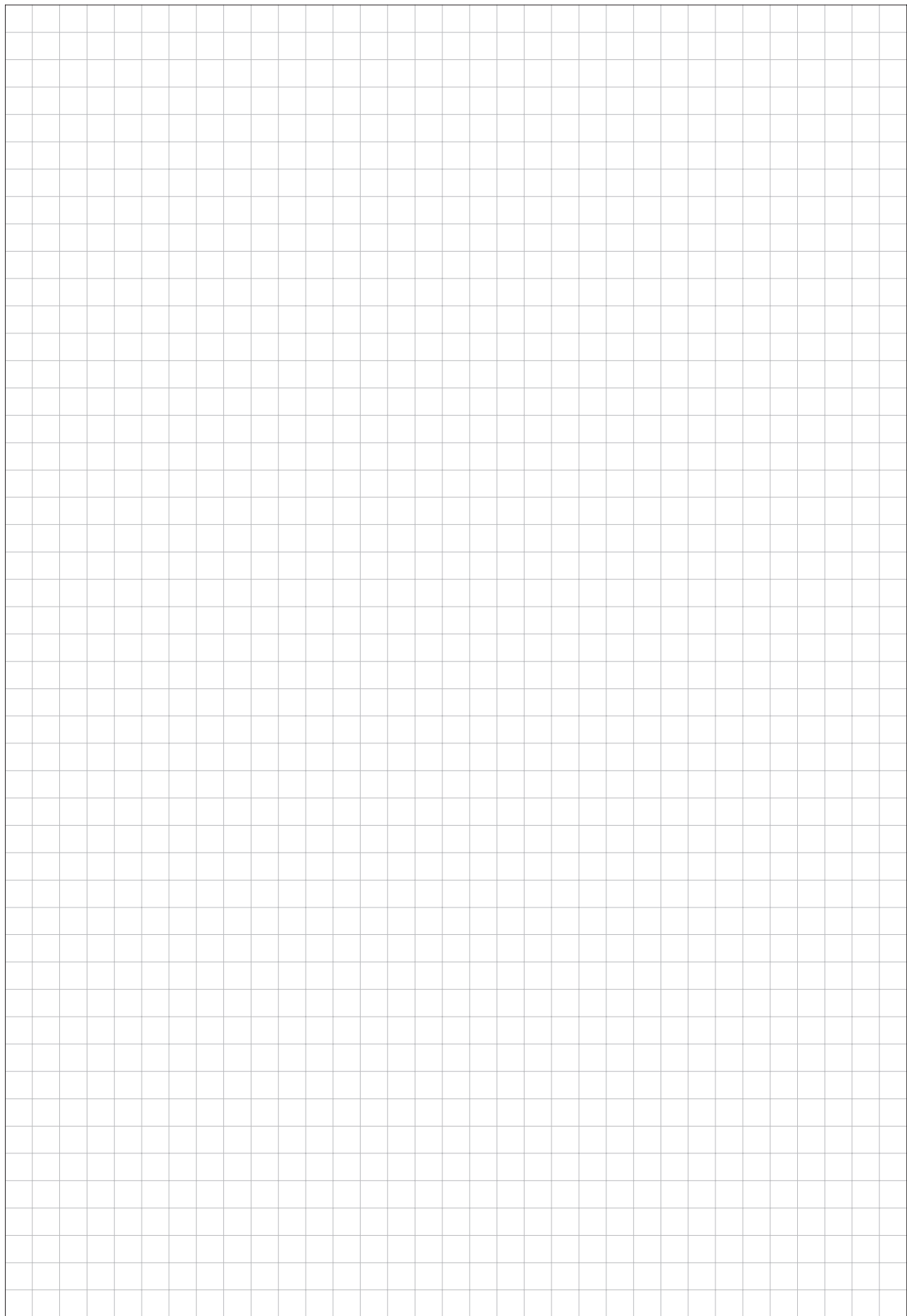



RCBO's - Residual current circuit breakers with overcurrent protection

EN/IEC 61009-1 6kA

Series HD90 For pulsating DC and AC fault currents

Series D90 For sinusoidal AC fault currents

Applications



Approvals / Marking



Add-on devices

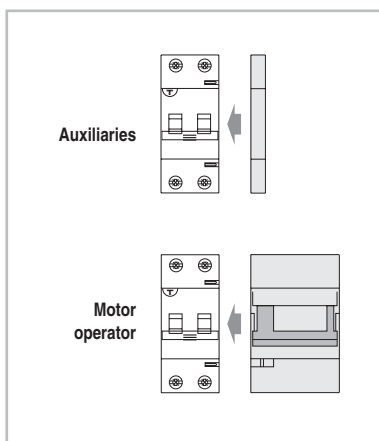

- Auxiliary contacts ● pg A.24
- Shunt trip ● pg A.24
- Undervoltage release ● pg A.24
- Panel board switch ● pg A.24
- Motor operator ● pg A.24

- Busbars ● chapter C
- Dimensions ● pg B.13

Performances

Thermal setting I_n	(A) 4 to 40
Residual current $I_{\Delta n}$	(mA) 10, 30, 300
Tripping characteristic	B-C
Rated voltage AC U_n	(V) 230
Minimum operating voltage U_{Bmin}	(V) 117
Mechanical/electrical endurance	20000/10000
Tropicalisation acc. to	
EN/IEC 60068-2-28/2-30 and DIN 40046	95%RH at 55°C
Terminal capacity flexible/rigid cable (mm²)	Top terminal: 16-25 Bottom terminal: 25-35
Poles	1+N
Nuisance tripping resistance	250A 8/20μs; 200A 0.5μs - 100kHz
Ambient temperature	(°C) Type AC: -5 upto 40 Type A: -25 upto 40
Weight	(g) 250

Short-circuit capacity

According to EN/IEC 61009-1 and EN/IEC 60898-1

Residual making and breaking capacity	$I_{\Delta m} = 6000A$
Short-circuit capacity	$I_{cn} = 6000A$ at 230V
Energy limiting class	3

According to IEC 60947-2

Short-circuit capacity	$I_{cu} = 10000A$ at 230V
-------------------------------	---------------------------

Series HD90 - D90

Resistance to surge currents up to 250A

B Characteristic 1P+N

230V

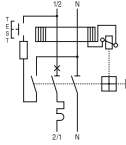

Thermal operating limit: 1.13 - 1.45 x In
Magnetic operating limit: 3 - 5 x In

Rated current [A]	Rated fault current [mA]	HD90 Type A		D90 Type AC		Pack.
		Cat. No.	Ref. No.	Cat. No.	Ref. No.	
6	10	HD90 B06/010	604580	D90 B06/010	604642	1
10	10	HD90 B10/010	604581	D90 B10/010	604643	1
13	10	HD90 B13/010	604582	D90 B13/010	604644	1
16	10	HD90 B16/010	604583	D90 B16/010	604645	1
20	10	HD90 B20/010	604584	D90 B20/010	604646	1
6	30	HD90 B06/030	604585	D90 B06/030	604647	1
10	30	HD90 B10/030	604586	D90 B10/030	604648	1
13	30	HD90 B13/030	604587	D90 B13/030	604649	1
16	30	HD90 B16/030	604588	D90 B16/030	604650	1
20	30	HD90 B20/030	604589	D90 B20/030	604651	1
25	30	HD90 B25/030	604590	D90 B25/030	604652	1
32	30	HD90 B32/030	604591	D90 B32/030	604653	1
40	30	HD90 B40/030	604592	D90 B40/030	604654	1
6	300	HD90 B06/300	604601	D90 B06/300	604663	1
10	300	HD90 B10/300	604602	D90 B10/300	604664	1
13	300	HD90 B13/300	604603	D90 B13/300	604665	1
16	300	HD90 B16/300	604604	D90 B16/300	604666	1
20	300	HD90 B20/300	604605	D90 B20/300	604667	1
25	300	HD90 B25/300	604606	D90 B25/300	604668	1
32	300	HD90 B32/300	604607	D90 B32/300	604669	1
40	300	HD90 B40/300	604608	D90 B40/300	604670	1

Resistance to surge currents up to 250A

C Characteristic 1P+N

230V

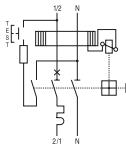

Thermal operating limit: 1.13 - 1.45 x In
Magnetic operating limit: 5 - 10 x In

4	10	HD90 C04/010	604609	D90 C04/010	604671	1
6	10	HD90 C06/010	604610	D90 C06/010	604672	1
10	10	HD90 C10/010	604611	D90 C10/010	604673	1
13	10	HD90 C13/010	604612	D90 C13/010	604674	1
16	10	HD90 C16/010	604613	D90 C16/010	604675	1
20	10	HD90 C20/010	604614	D90 C20/010	604676	1
4	30	HD90 C04/030	604615	D90 C04/030	604677	1
6	30	HD90 C06/030	604616	D90 C06/030	604678	1
10	30	HD90 C10/030	604617	D90 C10/030	604679	1
13	30	HD90 C13/030	604618	D90 C13/030	604680	1
16	30	HD90 C16/030	604619	D90 C16/030	604681	1
20	30	HD90 C20/030	604620	D90 C20/030	604682	1
25	30	HD90 C25/030	604621	D90 C25/030	604683	1
32	30	HD90 C32/030	604622	D90 C32/030	604684	1
40	30	HD90 C40/030	604623	D90 C40/030	604685	1
4	300	HD90 C04/300	604633	D90 C04/300	604695	1
6	300	HD90 C06/300	604634	D90 C06/300	604696	1
10	300	HD90 C10/300	604635	D90 C10/300	604697	1
13	300	HD90 C13/300	604636	D90 C13/300	604698	1
16	300	HD90 C16/300	604637	D90 C16/300	604699	1
20	300	HD90 C20/300	604638	D90 C20/300	604700	1
25	300	HD90 C25/300	604639	D90 C25/300	604701	1
32	300	HD90 C32/300	604640	D90 C32/300	604702	1
40	300	HD90 C40/300	604641	D90 C40/300	604703	1

Dimensions

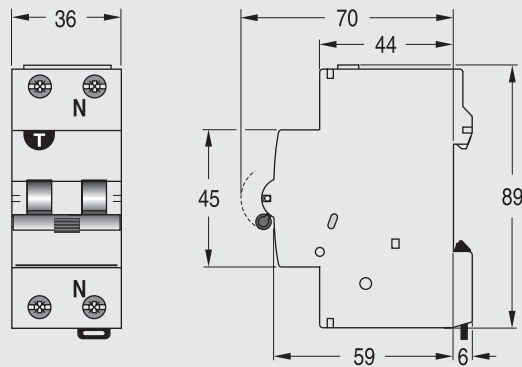

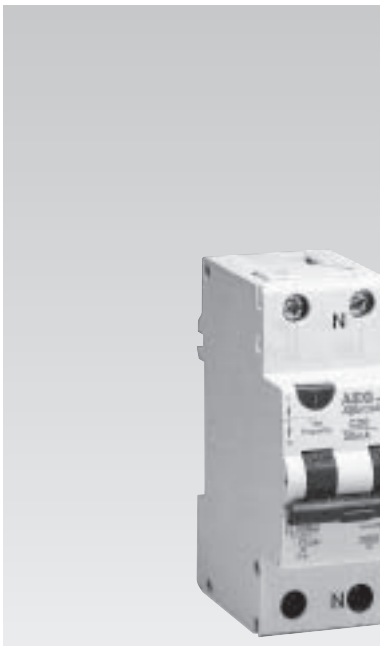

RCBO's - Residual current circuit breakers with overcurrent protection

EN/IEC 61009-1 10kA

Series HD90S For pulsating DC and AC fault currents

Series D90S For sinusoidal AC fault currents

Applications



Approval / Marking



Add-on devices

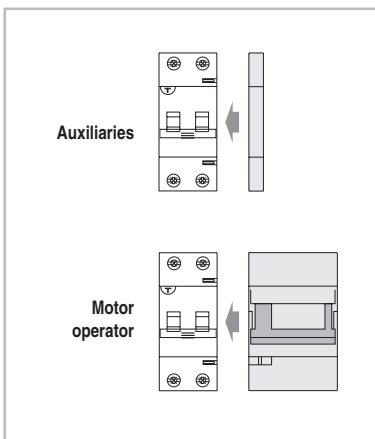

- Auxiliary contacts ● pg A.24
- Shunt trip ● pg A.24
- Undervoltage release ● pg A.24
- Panel board switch ● pg A.24
- Motor operator ● pg A.24

- Busbars ● chapter C
- Dimensions ● pg B.15

Performances

Thermal setting In	(A) 4 to 40
Residual current IΔn	(mA) 10, 30, 300
Tripping characteristic	B-C
Rated voltage AC Un	(V) 230
Minimum operating voltage U$_{Bmin}$	(V) 117
Mechanical/electrical endurance	20000/10000
Tropicalisation acc. to	
EN/IEC 60068-2-28/2-30 and DIN 40046	95%RH at 55°C
Terminal capacity flexible/rigid cable (mm²)	Top terminal: 16-25 Bottom terminal: 25-35
Poles	1+N
Nuisance tripping resistance	250A 8/20 μ s; 200A 0.5 μ s - 100kHz
Ambient temperature	(°C) Type AC: -5 upto 40 Type A: -25 upto 40
Weight	(g) 250

Short-circuit capacity

According to EN/IEC 61009-1 and EN/IEC 60898-1

Residual making and breaking capacity	I Δ m = 6000A
Short-circuit capacity	I $_{cn}$ = 10.000A at 230V
Selectivity class	3

According to EN/IEC 60947-2

Short-circuit capacity	I $_{cu}$ =15.000A at 230V
-------------------------------	----------------------------

Series HD90S - D90S

Resistance to surge currents up to 250A

B Characteristic 1P+N

240V

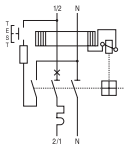

Thermal operating limit: 1.13 - 1.45 x I_n
Magnetic operating limit: 3 - 5 x I_n

Rated current [A]	Rated fault current [mA]	HD90S Type A		D90S Type AC		Pack.
		Cat. No.	Ref. No.	Cat. No.	Ref. No.	
6	10	HD90SB06/010	604704	D90SB06/010	604766	6
10	10	HD90SB10/010	604705	D90SB10/010	604767	6
13	10	HD90SB13/010	604706	D90SB13/010	604768	6
16	10	HD90SB16/010	604707	D90SB16/010	604769	6
20	10	HD90SB20/010	604708	D90SB20/010	604770	6
6	30	HD90SB06/030	604709	D90SB06/030	604771	6
10	30	HD90SB10/030	604710	D90SB10/030	604772	6
13	30	HD90SB13/030	604711	D90SB13/030	604773	6
16	30	HD90SB16/030	604712	D90SB16/030	604774	6
20	30	HD90SB20/030	604713	D90SB20/030	604775	6
25	30	HD90SB25/030	604714	D90SB25/030	604776	6
32	30	HD90SB32/030	604715	D90SB32/030	604777	6
40	30	HD90SB40/030	604716	D90SB40/030	604778	6
6	100	HD90SB06/100	604717	D90SB06/100	604779	6
10	100	HD90SB10/100	604718	D90SB10/100	604780	6
13	100	HD90SB13/100	604719	D90SB13/100	604781	6
16	100	HD90SB16/100	604720	D90SB16/100	604782	6
20	100	HD90SB20/100	604721	D90SB20/100	604783	6
25	100	HD90SB25/100	604722	D90SB25/100	604784	6
32	100	HD90SB32/100	604723	D90SB32/100	604785	6
40	100	HD90SB40/100	604724	D90SB40/100	604786	6
6	300	HD90SB06/300	604725	D90SB06/300	604787	6
10	300	HD90SB10/300	604726	D90SB10/300	604788	6
13	300	HD90SB13/300	604727	D90SB13/300	604789	6
16	300	HD90SB16/300	604728	D90SB16/300	604790	6
20	300	HD90SB20/300	604729	D90SB20/300	604791	6
25	300	HD90SB25/300	604730	D90SB25/300	604792	6
32	300	HD90SB32/300	604731	D90SB32/300	604793	6
40	300	HD90SB40/300	604732	D90SB40/300	604794	6

Resistance to surge currents up to 250A

C Characteristic 1P+N

240V

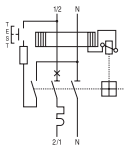

Thermal operating limit: 1.13 - 1.45 x I_n
Magnetic operating limit: 5 - 10 x I_n

4	10	HD90SC04/010	604733	D90SC04/010	604795	6
6	10	HD90SC06/010	604734	D90SC06/010	604796	6
10	10	HD90SC10/010	604735	D90SC10/010	604797	6
13	10	HD90SC13/010	604736	D90SC13/010	604798	6
16	10	HD90SC16/010	604737	D90SC16/010	604799	6
20	10	HD90SC20/010	604738	D90SC20/010	604800	6
4	30	HD90SC04/030	604739	D90SC04/030	604801	6
6	30	HD90SC06/030	604740	D90SC06/030	604802	6
10	30	HD90SC10/030	604741	D90SC10/030	604803	6
13	30	HD90SC13/030	604742	D90SC13/030	604804	6
16	30	HD90SC16/030	604743	D90SC16/030	604805	6
20	30	HD90SC20/030	604744	D90SC20/030	604806	6
25	30	HD90SC25/030	604745	D90SC25/030	604807	6
32	30	HD90SC32/030	604746	D90SC32/030	604808	6
40	30	HD90SC40/030	604747	D90SC40/030	604809	6
4	100	HD90SC04/100	604748	D90SC04/100	604810	6
6	100	HD90SC06/100	604749	D90SC06/100	604811	6
10	100	HD90SC10/100	604750	D90SC10/100	604812	6
13	100	HD90SC13/100	604751	D90SC13/100	604813	6
16	100	HD90SC16/100	604752	D90SC16/100	604814	6
20	100	HD90SC20/100	604753	D90SC20/100	604815	6
25	100	HD90SC25/100	604754	D90SC25/100	604816	6
32	100	HD90SC32/100	604755	D90SC32/100	604817	6
40	100	HD90SC40/100	604756	D90SC40/100	604818	6
4	300	HD90SC04/300	604757	D90SC04/300	604819	6
6	300	HD90SC06/300	604758	D90SC06/300	604820	6
10	300	HD90SC10/300	604759	D90SC10/300	604821	6
13	300	HD90SC13/300	604760	D90SC13/300	604822	6
16	300	HD90SC16/300	604761	D90SC16/300	604823	6
20	300	HD90SC20/300	604762	D90SC20/300	604824	6
25	300	HD90SC25/300	604763	D90SC25/300	604825	6
32	300	HD90SC32/300	604764	D90SC32/300	604826	6
40	300	HD90SC40/300	604765	D90SC40/300	604827	6

Dimensions

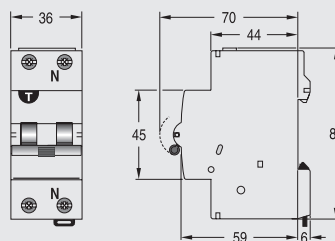



RCBO's - Electronic residual current circuit breakers with overcurrent protection

IEC 61009-1 6-10kA

Series DE90 For sinusoidal AC fault currents

Series DE90S For sinusoidal AC fault current

Applications



For use in consumer units and distribution boards

Marking



Performances

Thermal setting In	(A) 6, 10, 16, 20, 25, 32, 40
Residual current IΔn	(mA) 30
Tripping characteristic	B, C
Rated voltage AC U_n	(V) 265
Minimum operating voltage U_{Bmin}	(V) 195
Mechanical/electrical endurance	20000/10000
Tropicalisation acc. to EN/IEC 60068-2-28/2-30	95%RH at 55°C
Terminal capacity flexible/rigid cable (mm²)	Bottom terminal: 16-25
Poles	1+N (1 module)
Nuisance tripping resistance	250A 8/20 μ s
Ambient temperature	(°C) -5 upto 55
Weight	(g) 350

The earth reference cable (FE white) ensures protection against earth leakage in case of loss of supply neutral.

Short-circuit capacity

DE90 according to IEC 61009-1

Residual making and breaking capacity	I Δ m = 6000A
Short-circuit capacity	I _{cn} = 6000A at 240V
Energy limiting class	3

DE90S according to IEC 61009-1

Residual making and breaking capacity	I Δ m = 10.000A
Short-circuit capacity	I _{cn} = 10.000A at 240V
Energy limiting class	3

Dimensions ● pg B.17

Series DE90 - 6 kA

Unswitched neutral
1P+N
Characteristic C

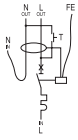

Rated current [A]	Rated fault current [mA]	DE90 Type AC		
		Cat. No.	Ref. No.	Pack.
6	30	DE90 C06/030	604989	1
10	30	DE90 C10/030	604990	1
16	30	DE90 C16/030	604991	1
20	30	DE90 C20/030	604992	1
25	30	DE90 C25/030	604993	1
32	30	DE90 C32/030	604994	1
40	30	DE90 C40/030	604995	1

Series DE90S - 10 kA

Unswitched neutral
1P+N
Characteristic C

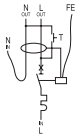

Rated current [A]	Rated fault current [mA]	DE90S Type AC		
		Cat. No.	Ref. No.	Pack.
6	30	DE90S C06/030	604982	1
10	30	DE90S C10/030	604983	1
16	30	DE90S C16/030	604984	1
20	30	DE90S C20/030	604985	1
25	30	DE90S C25/030	604986	1
32	30	DE90S C32/030	604987	1
40	30	DE90S C40/030	604988	1

Dimensions

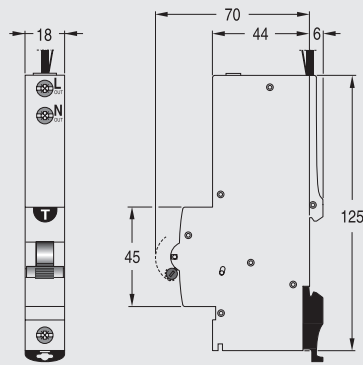



RCBO'S - Residual current circuit breakers with overcurrent protection

IEC 61009-1

Series HD62
Series HD63N

For pulsating DC and AC fault currents
2- and 3 pole protected

Applications



Approval / Marking



Performances

Number of poles	2P, 3P+N
Number of modules	HD62: 3 HD63N: 4
Type	A
Tripping time at $I_{\Delta n}$ (instantaneous)	< 40 ms
Rated voltage	(Vn) HD62: 230V~ HD63N: 400V~
Rated current at 30°C	(In) HD62: $6A \leq I_n \leq 32A$ HD63N: $10A \leq I_n \leq 25A$
Tripping characteristics	HD62: B/C HD63: C
Power Supply	Top/Bottom
Rated residual current $I_{\Delta n}$	(mA) 30
Mechanical/electrical endurance	20000/10000
Operating temperature	-25°/+40°
Rated frequency	50/60 Hz
Protection degree	(outside/inside electrical enclosure) IP20/IP40
Fire resistance (glow wire test)	960°C
Terminal capacity flexible/rigid cable	(mm ²) 1.5/25 - 1/35
Torque	3Nm
Dimensions HWD	(mm) HD62: 92x54x65 HD63N: 92x72x74
Weight	(g) HD62: 350 HD63N: 475

Short-circuit capacity

HD62 according to IEC 61009-1

Residual making and breaking capacity	$I_{\Delta m} = 3000A$
Rated breaking capacity	6000A
Selectivity class	3

HD63N according to IEC 61009-1

Residual making and breaking capacity	$I_{\Delta m} = 3000A$
Rated breaking capacity	6000A
Selectivity class	3

Series HD62-HD63N



	Rated current (A)	Rated fault current (mA)	B		C		Pack.
			Cat. No.	Ref. No.	Cat. No.	Ref. No.	
2P	6	30	HD62B06/030	568148	HD62C06/030	568141	1
	10	30	HD62B10/030	568149	HD62C10/030	568142	1
	16	30	HD62B16/030	568150	HD62C16/030	568143	1
	20	30	HD62B20/030	568151	HD62C20/030	568144	1
	25	30	HD62B25/030	568152	HD62C25/030	568145	1
	32	30	HD62B32/030	568153	HD62C32/030	568146	1



3P+N	10	30	-	-	HD63NC10/030	568195	1
	13	30	-	-	HD63NC13/030	568196	1
	16	30	-	-	HD63NC16/030	568197	1
	20	30	-	-	HD63NC20/030	568198	1
	25	30	-	-	HD63NC25/030	783521	1

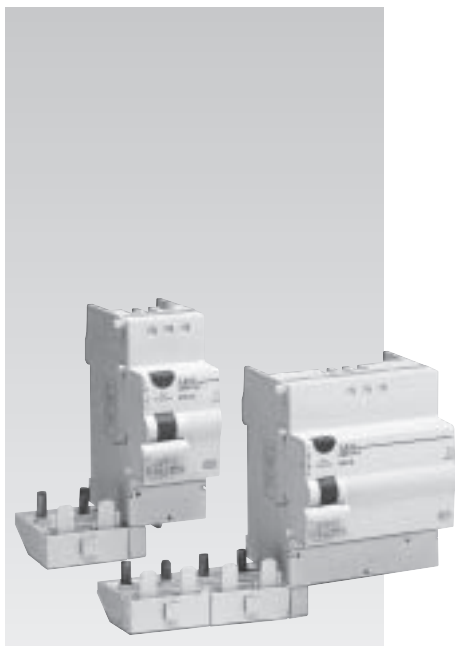

Applications



Marking



Add-on residual current circuit breakers

To be added on MCB Series E90

To be added on MCB's Series E880

EN/IEC 61009-1

Series HD92/93/94/95 For pulsating DC and AC fault currents

Series D92/93/94/95 For sinusoidal AC fault currents

Series HDS92/93/94/95 Time delayed trip for pulsating DC and AC fault currents

Series DS92/93/94/95 Time delayed trip for sinusoidal AC fault currents

Performances

Thermal setting I_n	(A) 32, 63
Residual current $I_{\Delta n}$	(mA) 30, 300
Rated voltage AC U_n	(V) 2P: 240/415 4P: 415
Minimum operating voltage U_{Bmin}	(V) 2P: 205 3P: 205 4P: 205
Mechanical/electrical endurance	20000/10000
Tropicalisation acc.to EN/IEC 60068-2/3 and DIN 40046	95%RH at 55°C
Terminal capacity flexible/rigid cable (mm²)	2P 32 & 63A: 25-35 4P 32 & 63A 4 mod.: 25-35
Poles	2, 4
Nuisance tripping resistance	Type A, AC: 250A 8/20μs; 200A 0.5μs - 100kHz Type HDS: 3000A 8/20μs
Ambient temperature	(°C) Type AC: -5 up to 55 Type A, HDS: -25 up to 55
Weight	(g) 2P: 250 4P: 340

Short-circuit capacity

Depends on the associated MCB

Residual making and breaking capacity

$I_{\Delta m}$

Short-circuit capacity

I_{cn}

	MCB			
	E90N	E90E	E90	E90S
$I_{\Delta m}$	3000	4500	6000	7500
I_{cn}	3000	4500	6000	10000

Dimensions ● pg B.21

Series HD92/93/94/95 - D92/93/94/95 - HDS92/93/94/95 - DS92/93/94/95

RATED CURRENT 32-63A



Resistance to surge currents up to 250A

2P
230-400V

4P
230-400V

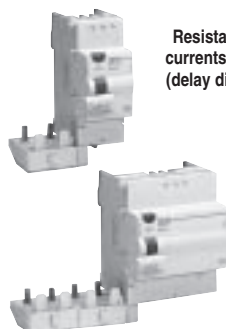

Resistance to surge currents up to 3000A (delay disconnected)

2P
230-400V

4P
230-400V

4P
230-400V

Rated current [A]	Rated fault current [mA]	HD92/94/95 Type A		D92/94/95 Type AC		Pack.	
		Cat. No.	Ref. No.	Cat. No.	Ref. No.		
32	30	HD92 32/030	604830	D92 32/030	604848	1	
	300	HD92 32/300	604832	D92 32/300	604850	1	
	30	HD92 63/030	604835	D92 63/030	604853	1	
	300	HD92 63/300	604837	D92 63/300	604855	1	
32 (2 mod.)	30	HD95 32/030	604886	D95 32/030	604895	1	
	300	HD95 32/300	604888	D95 32/300	604897	1	
	30	HD94 32/030	604900	D94 32/030	604918	1	
	300	HD94 32/300	604902	D94 32/300	604920	1	
	30	HD94 63/030	604909	D94 63/030	604923	1	
	300	HD94 63/300	604911	D94 63/300	604925	1	
	HDS92/94/95 Type S						
	32	300	HDS92 32/300	604841	-	-	1
300		HDS92 63/300	604845	-	-	1	
32 (2 mod.)	300	HDS95 32/300	604892	-	-	1	
	300	HDS94 32/300	604906	-	-	1	
63	300	HDS94 63/300	604915	-	-	1	
	500	HDS95 32/500	604893	-	-	1	
32	500	HDS94 32/500	604907	-	-	1	
	500	HDS94 63/500	604916	-	-	1	

RATED CURRENT 125A

2P

3P

4P

Delay disconnected

2P

3P

4P

Rated current [A]	Rated fault current [mA]	HD92/93/94 Type A		D92/93/94 Type AC		Pack.
		Cat. No.	Ref. No.	Cat. No.	Ref. No.	
125	30	HD92 125/030	676675	D92 125/030	676676	1
	300	HD92 125/300	676677	D92 125/300	676678	1
125	30	HD93 125/030	676681	D93 125/030	676682	1
	300	HD93 125/300	676683	D93 125/300	676684	1
125	30	HD94 125/030	676689	D94 125/030	676690	1
	300	HD94 125/300	676691	D94 125/300	676692	1
HDS92/93/94 Type A DS92/93/94 Type AC						
125	300	HDS92 125/300	676679	DS92 125/300	676680	1
	300	HDS93 125/300	676685	DS93 125/300	676686	1
125	1000	HDS93 125/1000	676687	DS93 125/1000	676688	1
	300	HDS94 125/300	676693	DS94 125/300	676694	1
125	1000	HDS94 125/1000	676695	DS94 125/1000	676696	1

Dimensions

2 Poles 32-63A

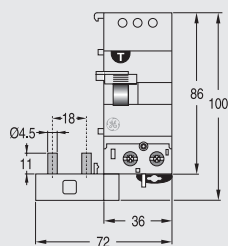

4 Poles 32A

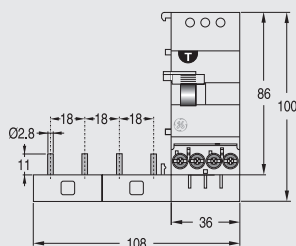

4 Poles 63A

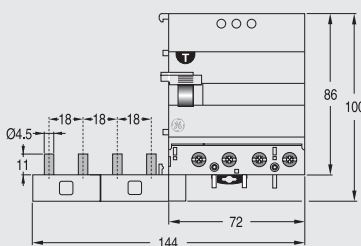

2/4 Poles 32-63A

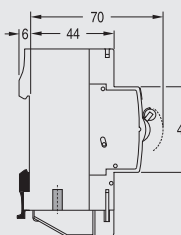



RCCB's - Residual current circuit breakers with screwless plug-in connection

EN/IEC 61008-1

Type A

Type S

Series EHFIP
Series ESHFIP

Applications



Approvals / Marking



Add-on devices

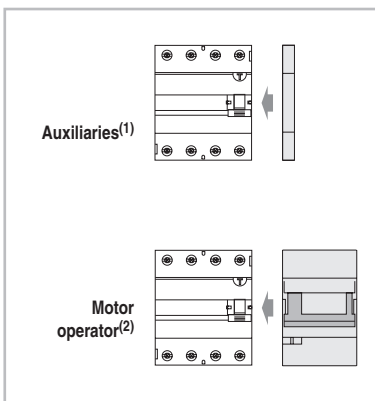

(1) Series H, SH, NF, NUVR, NFA

(2) Only at right side end of the extreme pin busbar

- Auxiliary contacts ● pg A.24
- Motor operator ● pg A.24
- Other auxiliary ● pg A.24
- Technical data ● pg B.22

- Busbars ● chapter C
- Dimensions ● pg B.23

Performances



Thermal setting I_n	(A) 25, 40, 63
Residual current $I_{\Delta n}$	(mA) 30, 100, 300
Rated voltage AC U_n	(V) 2P: 240 4P: 415
Minimum operating voltage U_{Bmin}	(V) 2P: 117 4P: 205
Mechanical/electrical endurance	20000/10000
Tropicalisation acc.to	95%RH at 55°C
EN/IEC 60068-2-28/2-30 and DIN 40046	
Terminal capacity flexible/rigid cable (mm ²)	35-50
Poles	2, 4
Nuisance tripping resistance	Type A Type S
Ambient temperature	(°C) -25 ... +50
Weight	(g) 2P: 248 4P: 364

Short-circuit capacity

Acc. EN/IEC 61008-1	
Making and breaking capacity	$I_m = 500A$ from 16 upto 40A $I_m = 10I_n$ from 63 upto 100A
Residual making and breaking capacity	$I_{\Delta m} = 500A$ from 16 upto 40A $I_{\Delta m} = 10I_n$ from 63 upto 100A
Short-circuit capacity	$I_{nc} = 10000A$ at 240/415V fuse 80A gG

Plug-in

Serie EHFIP - Type A

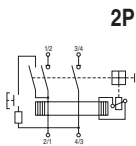

2P

In (A)	30 mA		100 mA		300 mA		Pack.
	Cat. No.	Ref. No.	Cat. No.	Ref. No.	Cat. No.	Ref. No.	
25	EHFIP25/030-2	678589	EHFIP25/100-2	678595	EHFIP25/300-2	678601	6
40	EHFIP40/030-2	678590	EHFIP40/100-2	678596	EHFIP40/300-2	678602	6
63	EHFIP63/030-2	678591	EHFIP63/100-2	678597	EHFIP63/300-2	678603	6

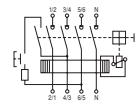

4P

25	EHFIP25/030-4	678592	EHFIP25/100-4	678598	EHFIP25/300-4	678604	3
40	EHFIP40/030-4	678593	EHFIP40/100-4	678599	EHFIP40/300-4	678605	3
63	EHFIP63/030-4	678594	EHFIP63/100-4	678600	EHFIP63/300-4	678606	3

Serie ESHFIP - Type S S

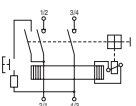

2P

In (A)	Cat. No.	Ref. No.	Cat. No.	Ref. No.	300 mA		Pack.
					Cat. No.	Ref. No.	
40					ESHFIP40/300-2	678607	6
63					ESHFIP63/300-2	678608	6

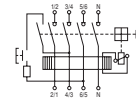

4P

40					ESHFIP40/300-4	678609	3
63					ESHFIP63/300-4	678610	3

Dimensions

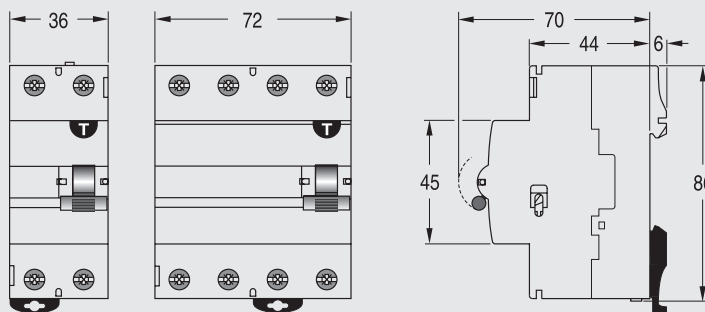

Technical data of screwless plug-in RCCB's - Fixwell™

Series			EHFIP, ESHFIP
Standards			EN 61008-1
Residual tripping characteristic			A, S
Tripping time at I Δ n	Instantaneous	(ms)	<40
	Selective	(ms)	>150
Rated current ⁽¹⁾		(A)	25, 40, 63
Rated residual current (I Δ n)		(mA)	30, 100, 300
Calibration temperature		(°C)	30
Number of poles versus modules			1
Rated voltage (Un)	2P AC	(V)	240
	4P AC	(V)	415
Frequency		(Hz)	50/60
Maximum service voltage (U _{bmax})		(V)	2P=265 / 4P=455
Minimum service voltage (U _{bmin})		(V)	2P=117 / 4P=205
Power supply			Top/Bottom
Rated making and breaking capacity (Im)		(A)	500 (or 10xIn)
Residual making and breaking capacity (I Δ m)		(A)	500 (or 10xIn)
Conditional short-circuit capacity (Inc)		(A)	10000 fuse 100A
Conditional residual short-circuit capacity (I Δ c)		(A)	10000
Isolator application			yes
Insulation degree	Insulation voltage	(V (DC))	500
	Shock voltage (1,2/50ms)	(kV)	8
	Insulation resistance	(M Ω)	1000
	Dielectric strength	(V)	2500
Shock resistance (in x, y, z direction) (EN/IEC 60077/16.3)			40g, 18 shocks 5 ms
Vibration resistance (in x, y, z direction) (EN/IEC 60068-2-6)			1.5g, 30 min, 0...80Hz
Endurance	Electrical at Un, In		10000
	Mechanical at Un, In		20000
Protection degree (outside/inside electrical enclosure)			IP20 / IP40
Self extinguish degree (acc. to UL94)			V2
Tropicalisation (EN/IEC 60068-2, DIN 40046)		(°C/RH)	+55/95%
Pollution degree (EN/IEC 60947-1)			3
Operating temperature ⁽²⁾			-25..+60
Storage temperature		(°C)	-25..+70
Terminal capacity			see page B.25
Add-on devices (side add-on)	Auxiliary contacts CA		yes
	Remote release NF		yes
	Undervoltage trip NUVR		yes
	Remote drive NFA		
	Panel board switch NLVS		yes
Busbar system bottom	Pin		yes
	Fork		no
Accessories			yes
Dimensions, weights, packaging			
	# Poles		2/4
	(HxDxW) 2P/4P	(mm)	88x68x36/73,2
	Weight	(g)	2P=248 / 4P=364
	Package		2P=1/6 / 4P=1/3
Approvals			VDE
CE-marking			yes

(1) Rating current derating as usual in function of installation conditions.

(2) With plug-in busbar: -25/+50°C

(3) With plug-in busbar only at **right extreme side** of each row. No pin busbars let through allowed.

Terminal capacity of plug-in RCCB's

Top terminals		
Ratings 25A, 40A and 63A:		
Cage terminals		
Rigid cable (min/max)	mm ²	1.5/50
Flexible cable (min/max)	mm ²	1.5/35
Recommended torque	Nm	2.5
Maximum torque	Nm	5

Bottom terminals			Pin busbar specifications
Ratings 25A, 40A and 63A:		Ratings 25A, 40A and 63A:	
Cage terminals ⁽¹⁾		Flat plug-in terminals ⁽²⁾	
Rigid cable (min/max)	mm ²	1/25	
Flexible cable (min/max)	mm ²	0.75/16	
Recommended torque	Nm	2.5	
Maximum torque	Nm	4.5	
		To insert AEG pin busbars, or other brands under following dimensions: Length = 11.5 ± 0.2mm Width = 4 ± 0.2 mm Thickness = 1.5 ± 0.05 mm Corners min. radius = 0.3 mm	

- (1) Bottom terminals provide a cage terminal to connect also cables to feed other rows /devices limited to rated current of the device.
 (2) Plug-in window terminals are only foreseen for pin busbars providing the incoming to several devices from the bottom side.
 Not intended for any other conductor with or without cable lugs or cable connectors.

How to mount the busbar into devices

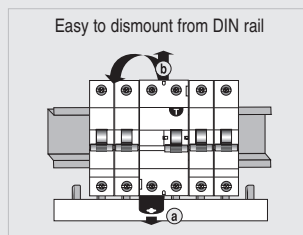
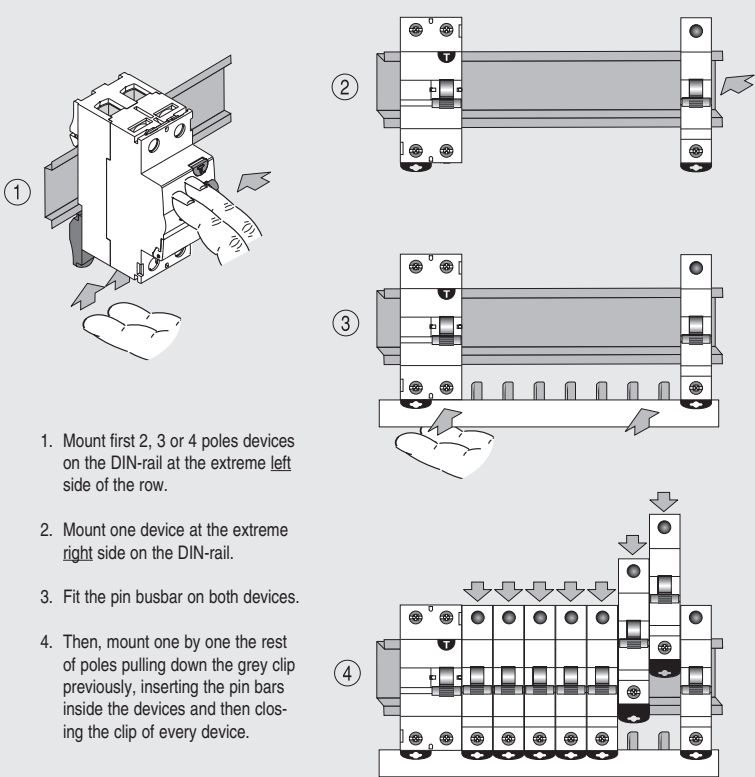



Applications



Reconnection relays

RCCB's EN/IEC 61008-1

Type A

Type S

TeleREC

Performance

Dimensions	3 modules
Unom.	(Vac) 220/240
Frequency	(Hz) 50-60
Reclose attempts	6
time intervals between re-close attempts	(sec) 10, 20, 30, 60, 120, 600
Security lock	Yellow safety lever
Status indication	Through voltage free output (Imax.) 2A (250V or 24Vdc) (Imin.) 20mA
Manual reclosing	Through external reset push-button

Characteristics

Status indicator

The yellow lever clearly indicates the status of the TeleREC. In position 1 the relay is ready to work, in position 0 the relay is blocked both electrically and mechanically.

Easy connection

The RCCB toggle slides easily into the toggle actuator of the relay.

One fits all

Both 2 modules and 4 modules RCCB's can be connected to the reconnection relay TeleREC.

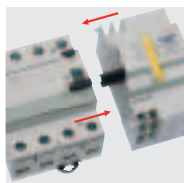

For the commercial/industrial market

Series TeleREC PLUS



Reconnection relay

In (A)

Cat. No.

Ref. No.

Pack.

Tele REC PLUS Motor

677144

1

+ The reconnection relay TeleREC PLUS can be easily coupled to any RCCB:

Series EFI - Type AC



2P
Type AC

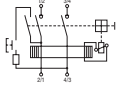

In (A)	10*/30mA		100mA		300mA		500mA		Pack.
	Cat. No.	Ref. No.	Cat. No.	Ref. No.	Cat. No.	Ref. No.	Cat. No.	Ref. No.	
16	EFI16/010-2	604446	-	-	-	-	-	-	6
25	DFI25/030-2	607130	EFI25/100-2	604455	DFI25/300-2	607132	DFI25/300-2	604468	6
40	DFI40/030-2	607131	EFI40/100-2	604456	DFI40/300-2	607133	DFI40/300-2	604469	6
63	EFI63/030-2	604449	EFI63/100-2	604457	EFI63/300-2	604465	EFI63/300-2	604470	6
80	EFI80/030-2	604450	EFI80/100-2	604458	EFI80/300-2	604466	EFI80/300-2	604471	6
100	EFI100/030-2	604451	EFI100/100-2	604459	EFI100/300-2	604467	EFI100/300-2	604472	6



4P
Type AC

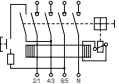

25	EFI25/030-4		EFI25/100-4		EFI25/300-4		EFI25/500-4		3
40	EFI40/030-4		EFI40/100-4		EFI40/300-4		EFI40/500-4		3
63	EFI63/030-4		EFI63/100-4		EFI63/300-4		EFI63/500-4		3
80	EFI80/030-4		EFI80/100-4		EFI80/300-4		EFI80/500-4		3
100	EFI100/030-4		EFI100/100-4		EFI100/300-4		EFI100/500-4		3

Series EHFI - Type A



2P
Type A

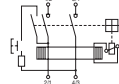

In (A)	10*/30mA		100mA		300mA		500mA		Pack.
	Cat. No.	Ref. No.	Cat. No.	Ref. No.	Cat. No.	Ref. No.	Cat. No.	Ref. No.	
16	EHFI16/010-2	604941	-	-	-	-	-	-	6
25	EHFI25/030-2	604942	EHFI25/100-2	604947	EHFI25/300-2	604416	EHFI25/500-2	604426	6
40	EHFI40/030-2	604943	EHFI40/100-2	604948	EHFI40/300-2	604417	EHFI40/500-2	604427	6
63	EHFI63/030-2	604944	EHFI63/100-2	604949	EHFI63/300-2	604418	EHFI63/500-2	604428	6
80	EHFI80/030-2	604945	EHFI80/100-2	604950	EHFI80/300-2	604419	EHFI80/500-2	604429	6
100	EHFI100/030-2	604946	EHFI100/100-2	604951	EHFI100/300-2	604420	EHFI100/500-2	604430	6



4P
Type A

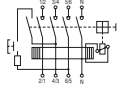

25	EHFI25/030-4	604478	EHFI25/100-4	604483	EHFI25/300-4	604493	EHFI25/500-4	604503	3
40	EHFI40/030-4	604479	EHFI40/100-4	604484	EHFI40/300-4	604494	EHFI40/500-4	604504	3
63	EHFI63/030-4	604480	EHFI63/100-4	604485	EHFI63/300-4	604495	EHFI63/500-4	604505	3
80	EHFI80/030-4	604481	EHFI80/100-4	604486	EHFI80/300-4	604496	EHFI80/500-4	604506	3
100	EHFI100/030-4	604482	EHFI100/100-4	604487	EHFI100/300-4	604497	EHFI100/500-4	604507	3

Series ESHFI - Type S



2P
Type S

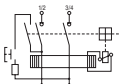

In (A)	300mA		500mA		Pack.
	Cat. No.	Ref. No.	Cat. No.	Ref. No.	
40	ESHFI40/300-2	604422	ESHFI40/500-2	604432	6
63	ESHFI63/300-2	604423	ESHFI63/500-2	604433	6
80	ESHFI80/300-2	604424	ESHFI80/500-2	604434	6
100	ESHFI100/300-2	604425	ESHFI100/500-2	604435	6



4P
Type S

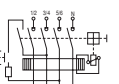

40	ESHFI40/300-4	604499	ESHFI40/500-4	604509	3
63	ESHFI63/300-4	604500	ESHFI63/500-4	604510	3
80	ESHFI80/300-4	604501	ESHFI80/500-4	604511	3
100	ESHFI100/300-4	604502	ESHFI100/500-4	604512	3

*On request: 1000 mA

Electrical diagram see page B.29

For the residential/commercial market

Series TeleREC BASIC - Type AC



2P
Type AC

4P
Type AC

In (A)	30 mA			Pack.
	Cat. No.	Ref. No.		
40	Tele REC BASIC 240/030	677147		1
40	Tele REC BASIC 440/030	677148		1

Electrical diagram

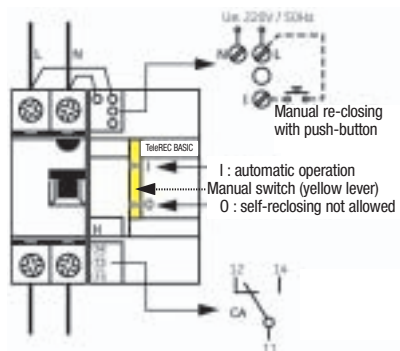

The complete solution in **only one device**:

- Total protection against person's indirect contacts.
- Safe reconnection of RCCB after trip by transitory earth leakage.
- Maintenance of power against trips provoked by high frequency earth leakages.
- Maintenance of power against shock waves up to 3000 A.

Especially designed for photovoltaic applications

Series TeleREC SOLAR



Reconnection relay

In (A)	Reconnection relay			Pack.
	Cat. No.	Ref. No.		
-	Tele REC SOLAR Motor	677145		1

+ The reconnection relay TeleREC SOLAR can be easily coupled to MCB's series EP100 UC:

Series EP100 UC - 10kA - characteristic B-C



2P
2 mod.

In (A)	B		C		Pack.
	Cat. No.	Ref. No.	Cat. No.	Ref. No.	
6	E92S UC B06	553290	E92S UC C06	553325	6
10	E92S UC B10	553292	E92S UC C10	553327	6
16	E92S UC B16	553294	E92S UC C16	553329	6
20	E92S UC B20	553295	E92S UC C20	553330	6
25	E92S UC B25	553296	E92S UC C25	553331	6
32	E92S UC B32	553297	E92S UC C32	553332	6
40	E92S UC B40	553298	E92S UC C40	553333	6
50	E92S UC B50	553299	E92S UC C50	553334	6
63	E92S UC B63	553300	E92S UC C63	553335	6

Electrical diagram

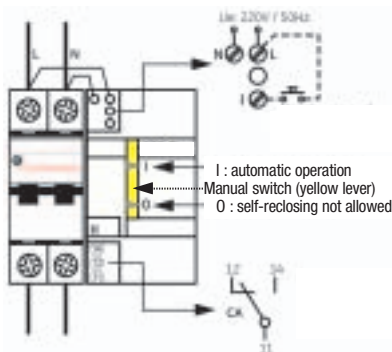

Only valid for photovoltaic application with MCB's Series EP102UC until 440Vdc ($I_{cc} < 2I_n$).
 The TeleREC SOLAR voltage is 230Vac.

Dimensional drawings

TeleREC - Reconnection relay

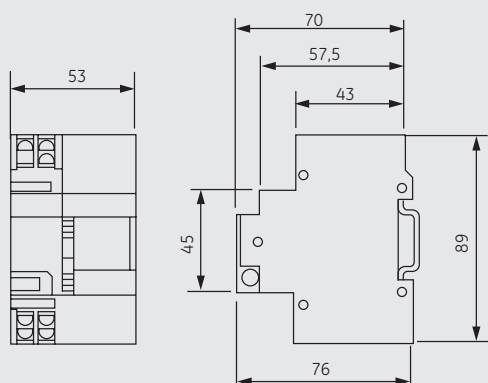

Electrical diagram

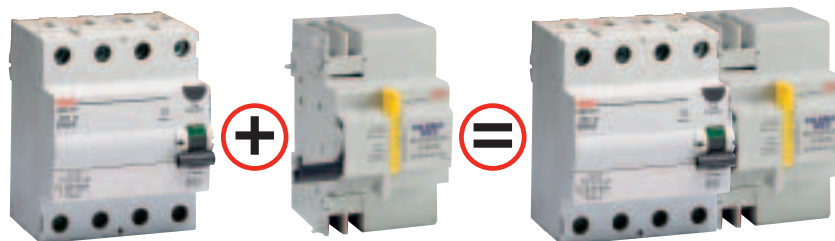
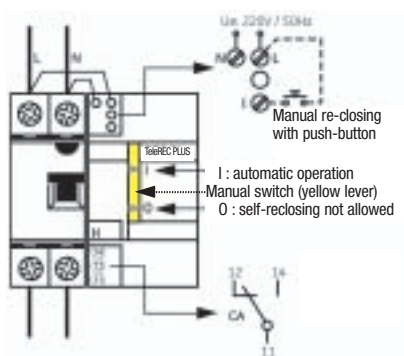

Notes

A large grid area for taking notes, consisting of approximately 25 columns and 40 rows of small squares.